



# BEVERAGE-AIR®

Project: _____	AIA#
Item: _____	
Location: _____	SIS#
Approved: _____	

UCF32AHC UNDERCOUNTER FREEZER

## UNDERCOUNTER FREEZER

### UCF32AHC Solid Door Freezer

### Hydrocarbon Series

MODEL:  
UCF32AHC



**7 Year Parts/Labor Warranty**  
**7 Year Compressor Warranty**

### CABINET CONSTRUCTION

- Stainless steel front, sides, top, door and grille (galvanized steel back & bottom)
- Interior liner is made of corrosion resistant aluminum
- Full electronic control
- Undercounter feature a 1/2" thick sub-top
- Interior thermometer is standard
- Self-closing door with 120° stay-open feature, on cartridge style hinges
- Door opening includes low wattage, anti-condensate heater
- Magnetic gasket attached to each door for positive seal
- 6" Casters, two (2) with brakes standard
- Two (2) epoxy-coated steel wire shelves
- Field-reversible door (hinge kit not included)

### OPTIONS & ACCESSORIES

- Stainless steel back
- Stainless steel interior
- Right or left hinged door
- Additional shelves
- Shelf clips
- Glass door option
- Lock
- Wire shelf divider
- 3" Casters
- 6" Legs (stainless steel, black or seismic/flange)
- Low profile casters
- Roller kit
- Remote option\* (see note on back on page)

### REFRIGERATION SYSTEM

- Uses environmentally friendly, energy efficient R290 refrigerant, and meets all regulatory requirements for CARB, SNAP, DOE & more
- Adaptive defrost
- Epoxy coated evaporator coil
- Freezers capable of maintaining product temperature of -10°F



Please verify qualifying units by visiting:  
[www.energystar.gov/cfs](http://www.energystar.gov/cfs)

3779 Champion Blvd., Winston-Salem, NC 27105  
1-888-845-9800 Fax: 1-336-245-6453  
Beverage-Air.com Sales@bevair.com



# BEVERAGE-AIR

MODEL	UCF32AHC
<b>EXTERNAL DIMENSIONAL DATA</b>	
Width Overall	32"
Depth Overall with Handle & Bumper	32"
Height Overall with 6" Casters	34 5/8"
Number of Doors	1
Depth with Door Open 90°	60 1/8"
Door Opening	27 5/8" x 21 5/8"
<b>INTERNAL DIMENSIONAL DATA</b>	
NET Capacity (cubic ft.)	7.2
Internal Width Overall (in)	28"
Internal Depth Overall (in)	18 1/4"
Internal Height Overall (in)	23"
Number of Shelves	2
<b>ELECTRICAL DATA</b>	
Full Load Amperes	4.0
<b>REFRIGERATION DATA</b>	
Horsepower	1/3+
Capacity (BTU/Hr)	1184
Heat Rejection (BTU/Hr)	1776
Charge (lbs/grams/ounces)	0.165 / 75 / 2.64
<b>SHIPPING DATA</b>	
Gross Weight - Crated	186 lbs
Height - Crated	34"
Width - Crated	32"
Depth - Crated	35"

\*NOTE: Remote units are field wired and come with 6" legs. Refrigerant must be specified at time of order.

We reserve the right to change specifications and product design without notice. Such revisions do not entitle the buyer to corresponding changes, improvements, additions or replacements for previously purchased equipment. Dimensional tolerances +/- 1/4". Metric dimensions (MM).

## Undercounter Freezer Model: UCF32AHC

### Model Views

Required Clearance: 3" Bottom & 2" Rear

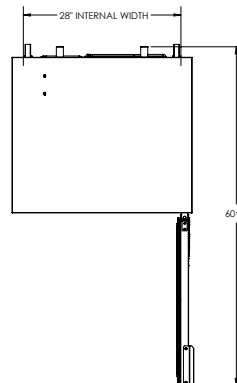

### PLAN VIEW

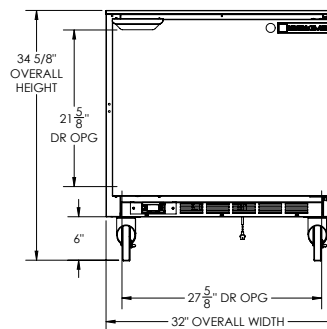

### ELEVATION VIEW

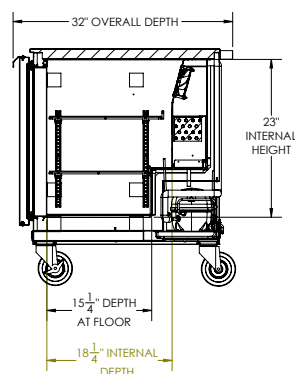

### SIDE VIEW

### ELECTRICAL CONNECTION



115/60/1  
NEMA 5-15P

Unit pre-wired at factory and include 8' long cord and plug set.

